



Motors & Spindles, Micro-grinders

Ultra-Precision Electrically / Pneumatically Driven

Precision & Reliability

NSK America

NAKANISHI
E4000 CONTROL UNIT

AMERICAN ROTARY TOOLS CO. (ARTCO TOOLS)
250 WEST DUARTE ROAD, #E
MONROVIA, CA USA 91016-7464

Tel: (626) 358-8466 Fax: (626) 358-0076
Toll Free USA Tel: (800) 624-2212 Fax: (800) 624-2210
Email: info@artcotools.com

2010/11
Edition
Email for Pricing and Delivery

Micro-Grinder

Electrically Driven



Emax EVOLution

1,000~40,000 min⁻¹(rpm)

ULTRA-PRECISION BRUSHLESS MICRO-GRINDER

- Digital display enhances safety and efficiency.
- Compact and functional design makes the unit portable.
- Soft touch switches permit easy operation and long service life.



1

EmaxEVO

ESPERT

ROTUS

ECOMO

IMPULSE

PRESTO II

SHEENUS 1150

SONIC CUTTER

2

iSpeed

E2530

E2550

E3000

E3200

E4000

3

MA SERIES

ø0.897"

ø1.0"

ø0.98"

ø1.18"

MS SERIES

ø0.75"

ø0.79"

ø0.87"

ø0.91"

ø1.0"

ø0.98"

ø1.18"

HIGH SPEED

AMX

4

HES

HTS

HPS

SMS

PL

5

AIR LINE KIT

6

PARTS

7

TECHNICAL DATA

8

APPLICATION EXAMPLES

INDEX

AMERICAN ROTARY TOOLS CO. (ARTCO TOOLS)
250 WEST DUARTE ROAD, #E
MONROVIA, CA USA 91016-7464

Tel: (626) 358-8466 Fax: (626) 358-0076
Toll Free USA Tel: (800) 624-2212 Fax: (800) 624-2210
Email: info@artcotools.com

ULTRA-PRECISION BRUSHLESS MICRO-GRINDER

“Emax EVOLution”

Emax EVOLution System Chart

1
EmaxEVO
ESPERT
ROTUS
ECOMO
IMPULSE
PRESTO II
SHEENUS
SONIC CUTTER
2
iSpeed
E2530
E2550
E3000
E3200
E4000
3
MA SERIES
ø0.897"
ø1.0"
ø0.98"
ø1.18"
MS SERIES
ø0.75"
ø0.79"
ø0.87"
ø0.91"
ø1.0"
ø0.98"
ø1.18"
HIGH SPEED
AMX
4
HES
HTS
HPS
SMS
PL
5
AIR LINE KIT
6
PARTS
7
TECHNICAL DATA
8
APPLICATION EXAMPLES
INDEX

CAT. No.	Model	Price
RE11008	IR-310	
RE10178	IH-300	
RE10188	HG-200	
25,000 min ⁻¹ (rpm) Max. (*1)		
RE10235	BMH-300	
35,000 min ⁻¹ (rpm) Max. (*1)		
RE10247	MFC-300S	
15,000 min ⁻¹ (rpm) Max. (*1)		
RE10252	MFC-300M	
15,000 min ⁻¹ (rpm) Max. (*1)		
RE10182	IC-300	
35,000 min ⁻¹ (rpm) Max. (*1) 20,000 min ⁻¹ (rpm) Max. (*2)		
RE10266	KC-300	
35,000 min ⁻¹ (rpm) Max. (*1) 20,000 min ⁻¹ (rpm) Max. (*2)		
LS10815	LS-100	
30,000 min ⁻¹ (rpm) Max. (*1)		
LS51307	ML-8	
35,000 min ⁻¹ (rpm) Max. (*1) 30,000 min ⁻¹ (rpm) Max. (*2)		
LS11380	SLS-16	
35,000 min ⁻¹ (rpm) Max. (*1)		
RE18060	HA-500	
20,000 min ⁻¹ (rpm) Max. (*1) 16,000 min ⁻¹ (rpm) Max. (*2)		
KBS61065	KBS-101	
35,000 min ⁻¹ (rpm) Max. (*1)		

Attachment

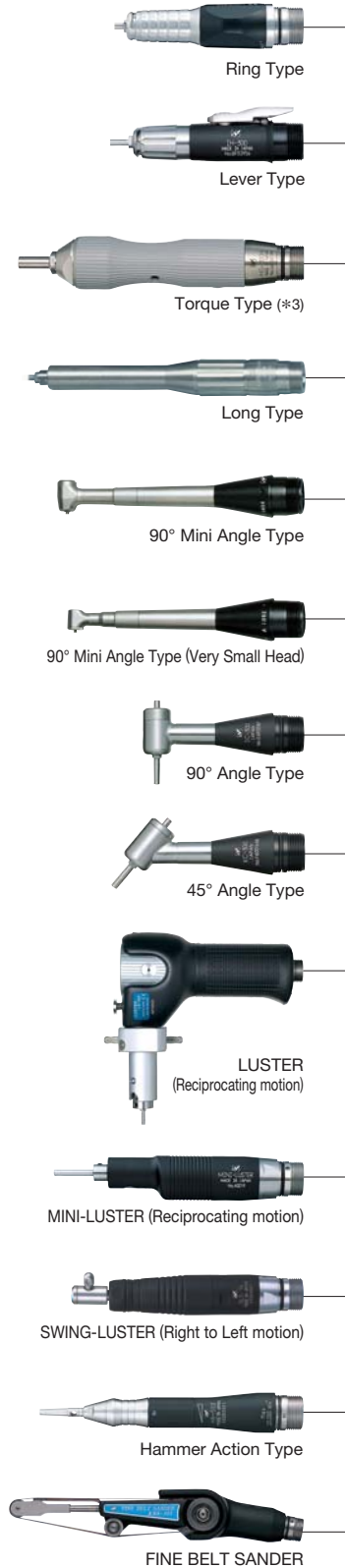

- Wide selection of attachments available depending on the application.

Speed Reducer · Extension Joint

Extension Joint
RE10210 CN-01
35,000 min⁻¹(rpm) Max. (*1)

1/4 Speed Reducer
RO10214 RG-01
30,000 min⁻¹(rpm) Max. (*1)

1/15 Speed Reducer
RO10228 RG-02
30,000 min⁻¹(rpm) Max. (*1)

* May be connected between the motor and the attachment as required for increased torque.

*Maximum Allowable Speed, continuous use may change depending on the material being cut and other application variables.

*1 : Maximum Allowable Speed, intermittent use. *2 : Maximum Allowable Speed, continuous use. *3 : Use 6mm torque Type HG-200 to connect ENK-250T

1
EmaxEVO
ESPERT
ROTUS
ECOMO
IMPULSE
PRESTO II
SHEENUS neo
SONIC CUTTER
2
iSpeed
E2530
E2550
E3000
E3200
E4000
3
MA SERIES
ø0.897"
ø1.0"
ø0.98"
ø1.18"
MS SERIES
ø0.75"
ø0.79"
ø0.87"
ø0.91"
ø1.0"
ø0.98"
ø1.18"
HIGH SPEED
AMX
4
HES
HTS
HPS
SMS
PL
5
AIR LINE KIT
6
PARTS
7
TECHNICAL DATA
8
APPLICATION EXAMPLES
INDEX

Motor		
CAT. No.	Model	Price

Control Unit		
CAT. No.	Model	Price



• Standard Type Motor with Cord
1,000~40,000 min⁻¹(rpm)

8086	ENK-410S	
------	----------	--



• Torque Type Motor with Cord
1,000~25,000 min⁻¹(rpm)

8087	ENK-250T	
------	----------	--



8224 (120V)	NE249 120	
----------------	-----------	--

“Emax EVOLution” FEATURES

- Digital display enhances safety and efficiency.
- Compact and functional design makes the unit portable.
- Soft touch switches permit easy operation and long service life.

New Advanced Design Control Unit

Advanced Control Function

Upgraded Digital Display.
EVOLUTION Speed Control with Flash Load Indicator.



Motor speed digital display

Load Meter

- : Continuous load area
- : Intermittent load area
- : Overload

Diversity for work efficiency

2 Motors A and B can be connected to cover multiple work requirements.

*Simultaneous motor operation is not allowable



Memory Speed Function FiXpeed®

An exclusive new feature of the Emax EVOLution is the FiXpeed® system allowing independent foot switch operation for the A and B Motors. A Motor foot switch can be on/off and B Motor foot switch can be variable speed. This function brings unprecedented versatility and workability.

Advanced User Friendly Design

New Industrial Design.
EVOLUTION new user friendly case meets design and performance requirements.



Auto Cruise Function

The control unit is equipped with an Auto Cruise Function. While using foot control for work, anyone could fix the motor at any speed by the embedded motor switch.

Once speed is set, foot pedal control is not required. This function eliminates foot fatigue during operation.

Forward / Reverse Select Switch

Forward/Reverse rotation can be selected.

ø4.72" Speed Control Volume

Easy to operate by one finger

Memory Speed Function FiXpeed®

Motor B ON/OFF Function

Motor A ON/OFF Function

Emax EVOLution Control Unit

CAT. No.	Model	Specifications	Price
8224 (120V)	NE249 120	<ul style="list-style-type: none"> • Weight : 5 lb. 1.13 oz. • Power Source : AC120V, 50-60Hz • Dimensions : W5.12" x D10.0" x H3.82" 	

Accessories : Handpiece Holder : 1 pc., Handpiece Stand : 1 pc.
 Power Supply Cord : 1 pc.

Ultra-Precision Micro-Grinder



NAKANISHI Smart Switch

The switch provides a click sensation. A confirmation tone is reacted by the control unit when the switch is operated. The motor type is distinguishable by the switch color.



One Touch Tool Changing

- Ring Type (IR-310)
Easy twist open/close chuck



Various Collet Size

Various sizes ranging from ultra-small diameter (0.3 mm) are available for each attachment. Furthermore, collet replacement can be easily performed without wrench.

Special Dust Protection Mechanism (patented)

The chuck section of Emax EVOLUTION has a special built-in dust protection mechanism that prevents entry of foreign materials such as chips, and provides superior durability as well.

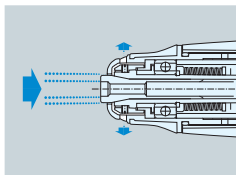

Emax EVOLUTION vs E-max Torque Characteristic

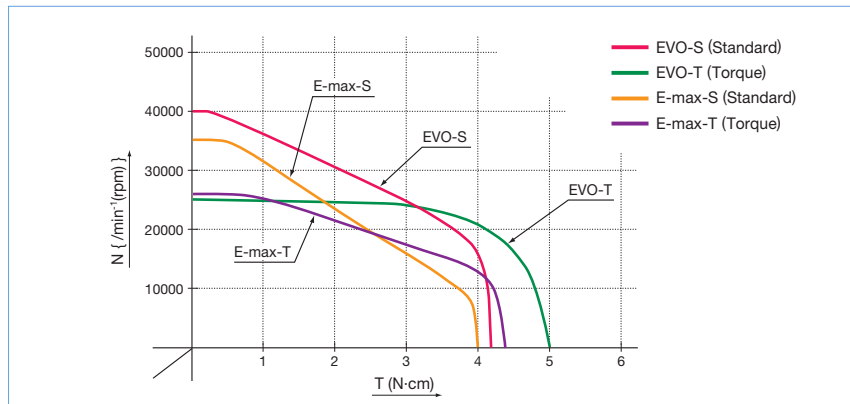

2 Types of Motors

Provides choice of various applications.

- Standard Type Motor 1,000-40,000 min⁻¹ (rpm) (ENK-410S) **Blue**
- Torque Type Motor 1,000-25,000 min⁻¹ (rpm) (ENK-250T) **Green**

*** Exclusive use for Emax EVOLUTION**

Emax EVOLUTION and Electer E-max have different motor cord pin configurations.



Emax EVOLUTION



Electer E-max

Excellent Durability

- High performance brushless motor eliminates the need of changing carbon brushes.
- RPM variation is minimal even when load changes. Allowing difficult and stable cutting in stress free motion. Suitable performance for finish grinding.
- Provides superior quietness and smoothness from low speed to high speed.

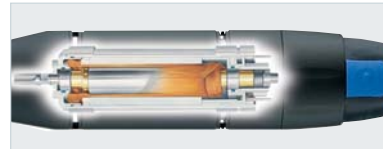

16 Types of Attachments for All Types of Applications

Capable of infinite applications with 13 different handpieces and 3 types of intermediate attachments.

*Interchangeable with attachments form the E-max and ROTUS system.

1
EmaxEVO

ESPERT
ROTUS
ECOMO
IMPULSE
PRESTO II
SHEENUS H90
SONIC CUTTER

2
iSpeed
E2530
E2550
E3000
E3200
E4000

3
MA SERIES
ø0.897"
ø1.0"
ø0.98"
ø1.18"
MS SERIES
ø0.75"
ø0.79"
ø0.87"
ø0.91"
ø1.0"
ø0.98"
ø1.18"
HIGH SPEED
AMX

4
HES
HTS
HPS
SMS
PL

5
AIR LINE KIT

6
PARTS

7
TECHNICAL DATA

8
APPLICATION EXAMPLES
INDEX

“Emax EVOLution” STANDARD SET

1

EmaxEVO

ESPERT
ROTUS
ECOMO
IMPULSE
PRESTO II
SHEENUS neo
SONIC CUTTER

2

iSpeed
E2530
E2550
E3000
E3200
E4000

3

MA SERIES
ø0.897"
ø1.0"
ø0.98"
ø1.18"
MS SERIES
ø0.75"
ø0.79"
ø0.87"
ø0.91"
ø1.0"
ø0.98"
ø1.18"
HIGH SPEED
AMX

4

HES
HTS
HPS
SMS
PL

5

AIR LINE KIT

6

PARTS

7

TECHNICAL DATA

8

APPLICATION EXAMPLES

INDEX

Emax EVOLution RING TYPE STANDARD SET

NEW



Capabilities for a wide variety of applications.
Excellent balance and motor power for smooth speed and handling.

1,000~40,000 min⁻¹(rpm)

* New Ring Type IR-310 is the standard attachment for Emax EVOLution standard set EV410-IR

CAT.No.	8231 (120V)	Model	EV410-IR	Price	995.00
		Attachment	IR-310	Motor	ENK-410S
Standard Equipment		Micro Grinder (IR-310+ENK-410S) : 1 pc. Collet ø1/8" (CHH-3.175), ø2.35 mm (CHH-2.35) : 1 pc. each Control Unit (NE249 120) : 1 pc. Handpiece Holder : 1 pc. Handpiece Stand : 1 pc. Power Supply Cord : 1 pc. Wrench (7 x 5.1) : 1 pc. Pin Wrench (K-233) : 1 pc. L Shaped Wrench : 1 pc.			

Emax EVOLution RING TYPE TORQUE SET

NEW



For heavy duty and larger tools, Torque type promises to extend operation ranges.

1,000~25,000 min⁻¹(rpm)

* New Ring Type IR-310 is the standard attachment for Emax EVOLution torque set EV250-IR

CAT.No.	8232 (120V)	Model	EV250-IR	Price	1,190.00
		Attachment	IR-310	Motor	ENK-250T
Standard Equipment		Micro Grinder (IR-310+ENK-250T) : 1 pc. Collet ø1/8" (CHH-3.175), ø2.35 mm (CHH-2.35) : 1 pc. each Control Unit (NE249 120) : 1 pc. Handpiece Holder : 1 pc. Handpiece Stand : 1 pc. Power Supply Cord : 1 pc. Wrench (7 x 5.1) : 1 pc. Pin Wrench (K-233) : 1 pc. L Shaped Wrench : 1 pc.			

"Emax EVOLution" MOTOR

Motor for *Emax EVOLution* (Electrically Driven)

- **NAKANISHI Smart Switch.**
- **High performance samarium cobalt magnet.**
- **High accuracy, lightweight, compact, high reliability and superior durability.**
- **Major reduction of RF noise.**
- **Provides extremely quiet operation from low to high speed with stepless speed adjustment.**

Motor Specifications

Motor Model	ENK-410S	ENK-250T
Speed	1,000~40,000 min ⁻¹ (rpm)	1,000~25,000 min ⁻¹ (rpm)
Weight (w/o Cord)	3.17 oz.	5.19 oz.
Max. Torque	4.3 cN·m	4.8 cN·m
Output Power	73W	76W

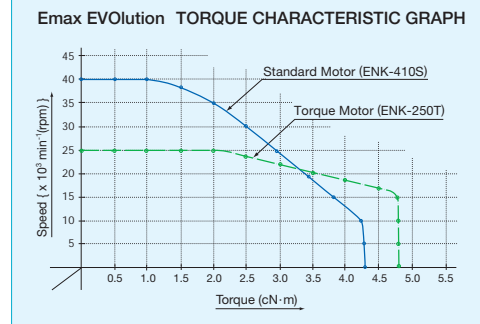

CAT. No. 8086 STANDARD TYPE MOTOR ENK-410S

NEW



1,000~40,000 min⁻¹(rpm)

- Excellent combination of high speed, lightweight, small diameter and high torque. This lightweight and compact general-use type is perfect for precision work.

CAT. No.	Model	Standard Accessories	Price
8086	ENK-410S	• Straight Cord : 4.5 ft	

CAT. No. 8087 TORQUE TYPE MOTOR ENK-250T

NEW



1,000~25,000 min⁻¹(rpm)

- Combines the best of both high speed and high torque. It is perfect for applications requiring large burs.

CAT. No.	Model	Standard Accessories	Price
8087	ENK-250T	• Straight Cord : 4.5 ft	

AMERICAN ROTARY TOOLS CO.

Toll Free USA Tel: (800) 624-2212

* Order by catalog number.

1-p7

1
EmaxEVO
ESPERT
ROTUS
ECOMO
IMPULSE
PRESTO II
SHEENUS H90
SONIC CUTTER
2
iSpeed
E2530
E2550
E3000
E3200
E4000
3
MA SERIES
ø0.897"
ø1.0"
ø0.98"
ø1.18"
MS SERIES
ø0.75"
ø0.79"
ø0.87"
ø0.91"
ø1.0"
ø0.98"
ø1.18"
HIGH SPEED
AMX
4
HES
HTS
HPS
SMS
PL
5
AIR LINE KIT
6
PARTS
7
TECHNICAL DATA
8
APPLICATION EXAMPLES
INDEX

"Emax EVOLution" ATTACHMENTS

1

EmaxEVO

ESPERT

ROTUS

ECOMO

IMPULSE

PRESTO II

SHEENUS neo

SONIC CUTTER

2

iSpeed

E2530

E2550

E3000

E3200

E4000

3

MA SERIES

ø0.897"

ø1.0"

ø0.98"

ø1.18"

MS SERIES

ø0.75"

ø0.79"

ø0.87"

ø0.91"

ø1.0"

ø0.98"

ø1.18"

HIGH SPEED

AMX

4

HES

HTS

HPS

SMS

PL

5

AIR LINE KIT

6

PARTS

7

TECHNICAL DATA

8

APPLICATION EXAMPLES

INDEX

CAT. No. RE11008 RING TYPE ATTACHMENT IR-310



● Perfectly designed for powerful and delicate cutting and grinding, and made slim and light weight for comfortable gripping.

- Weight : 3.25 oz.
- Simple, no wrench bur replacement.
- Wrench is not required to exchange the chuck.
- Collet
- Standard Size : ø1/8" (CHH-3.175), ø2.35 mm (CHH-2.35)
- Optional Collets: CHH-□□ are shown in page (6-p2)

Ring Type Attachment

CAT. No.	Model	Standard Accessories	Price
RE11008	IR-310	• Collet ø1/8" (CHH-3.175), ø2.35 mm (CHH-2.35) : 1 pc. each • Wrench (7 x 5.1) : 1 pc. • Pin Wrench (K-233) : 1 pc. • L Shaped Wrench : 1 pc.	

CAT. No. RE10178 LEVER TYPE ATTACHMENT IH-300



● Perfectly designed for powerful and delicate cutting and grinding, and made slim and light weight for comfortable gripping.

- Weight : 2.19 oz.
- Just turn the lever to exchange the bur.
- Wrench is not required to exchange the chuck.
- Collet
- Standard Size : ø1/8" (CHH-3.175), ø2.35 mm (CHH-2.35)
- Optional Collets: CHH-□□ are shown in page (6-p2)

Lever Type Attachment

CAT. No.	Model	Standard Accessories	Price
RE10178	IH-300	• Collet ø1/8" (CHH-3.175), ø2.35 mm (CHH-2.35) : 1 pc. each • Wrench (7 x 5.1) : 1 pc. • Pin Wrench (K-233) : 1 pc.	

CAT. No. RE10188 TORQUE TYPE ATTACHMENT HG-200

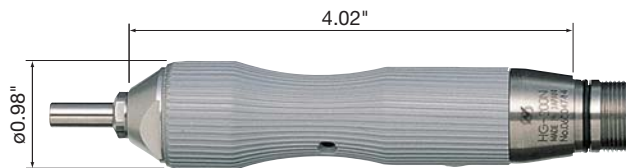

25,000 min⁻¹(rpm) Max. (*1)



● The resistance produced by cutting and grinding is absorbed by a special rubber grip to eliminate slipping.

- Chuck is tightened by a Wrench.
- Weight : 7.41 oz.
- Collet
- Standard Size : ø1/4" (CHG-6.35)
- Optional Collets: CHG-□□ are shown in page (6-p2)

Torque Type Attachment

*Use 6mm torque Type HG-200 to connect ENK-250T

CAT. No.	Model	Standard Accessories	Price
RE10188	HG-200	• Collet ø1/4" (CHG-6.35) : 1 pc. • Wrench (10 x 10) : 1 pc. • Bar Wrench (K-212) : 1 pc. • Pin Wrench (K-233) : 1 pc.	

"Emax EVOLution" ATTACHMENTS

CAT. No. RE10235 For Deep Hole Grinding LONG ATTACHMENT BMH-300



● This unique slim body makes it ideal for cutting and grinding the bottom surface of deep ribs or holes.

- Weight : 5.50 oz.
- Wrench is not required to exchange the chuck.
- Collet
- Standard Size : $\phi 1/8"$ (CHM-3.175)
- Optional Collets : CHM-□□ are shown in page (6-p4)

Long Attachment for Deep Hole Grinding

CAT. No.	Model	Standard Accessories	Price
RE10235	BMH-300	<ul style="list-style-type: none"> • Collet $\phi 1/8"$ (CHM-3.175) : 1 pc. • Wrench (7 x 5.1), (6 x 4.5) : 1 pc. each • Pin Wrench (K-233) : 1 pc. 	

CAT. No. RE10247 For Chamfering Deep Hole 90° MINI ANGLE TYPE ATTACHMENT MFC-300S



● Ideal for chamfering and deburring the inside of slit pipe.

- Minimum Inner Diameter : $\phi 0.79"$
- Weight : 1.76 oz.
- Standard Collet : $\phi 1.6$ mm (K-252)
- Speed Reduction Ratio : 10/11

90° MINI ANGLE TYPE Attachment for Chamfering Deep Hole, Bur Only $\phi 1.6$ mm

CAT. No.	Model	Standard Accessories	Price
RE10247	MFC-300S	<ul style="list-style-type: none"> • Collet $\phi 1.6$ mm (K-252) : 1 pc. • Chuck Wrench (K-232) : 1 pc. • Pin Wrench (K-233) : 1 pc. 	

CAT. No. RE10252 For Chamfering Deep Hole 90° MINI ANGLE TYPE ATTACHMENT MFC-300M



● The smallest 90° Angle type head is suitable for chamfering and deburring the inside of the slit pipe.

- Minimum Inner Diameter : $\phi 0.51"$
- Weight : 1.66 oz.
- Standard Collet : $\phi 1.6$ mm (K-253)
- Speed Reduction Ratio : 10/11

90° MINI ANGLE TYPE Attachment for Chamfering Deep Hole, Bur Only $\phi 1.6$ mm (Very Small Head)

CAT. No.	Model	Standard Accessories	Price
RE10252	MFC-300M	<ul style="list-style-type: none"> • Collet $\phi 1.6$ mm (K-253) : 1 pc. • Chuck Wrench (K-232) : 1 pc. • Pin Wrench (K-233) : 1 pc. 	

AMERICAN ROTARY TOOLS CO. Toll Free USA Tel: (800) 624-2212

*Maximum Allowable Speed, continuous use may change depending on the material being cut and other application variables.

*1 : Maximum Allowable Speed, intermittent use.
*2 : Maximum Allowable Speed, continuous use.

* Order by catalog number.

1
EmaxEVO
ESPERT
ROTUS
ECOMO
IMPULSE
PRESTO II
SHEENUS 190
SONIC CUTTER
2
iSpeed
E2530
E2550
E3000
E3200
E4000
3
MA SERIES
$\phi 0.897"$
$\phi 1.0"$
$\phi 0.98"$
$\phi 1.18"$
MS SERIES
$\phi 0.75"$
$\phi 0.79"$
$\phi 0.87"$
$\phi 0.91"$
$\phi 1.0"$
$\phi 0.98"$
$\phi 1.18"$
HIGH SPEED
AMX
4
HES
HTS
HPS
SMS
PL
5
AIR LINE KIT
6
PARTS
7
TECHNICAL DATA
8
APPLICATION EXAMPLES
INDEX

"Emax EVOLution" ATTACHMENTS & ACCESSORIES

CAT. No. RE10182 90° ANGLE ATTACHMENT IC-300



35,000 min⁻¹(rpm) Max. (*1)
20,000 min⁻¹(rpm) Max. (*2)

Drive Motor & Control Unit

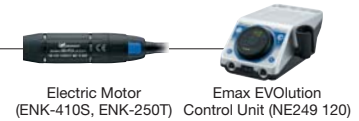

Electric Motor (ENK-410S, ENK-250T) Emax EVOLution Control Unit (NE249 120)

*For the details of above micromotor, refer to the following page (1-p7)

- 90° Angle attachment with $\phi 1/8"$ ($\phi 3.175$ mm) Collet. Most suitable for polishing flat surfaces, corners and internal surfaces of pipes with paper disk mounted on rubber pad.



- Reduction Ratio : 3/4
- Weight : 1.59 oz.
- Collet
Standard Size : $\phi 1/8"$ (CHC-3.175)
Optional Collets : CHC-□□ are shown in page (6-p2)

90° Angle Attachment

CAT. No.	Model	Standard Accessories	Price
RE10182	IC-300	<ul style="list-style-type: none"> • Collet $\phi 1/8"$ (CHC-3.175) : 1 pc. • Standard Accessories : 1 set • Chuck Wrench (K-231) : 1 pc. • Pin Wrench (K-233) : 1 pc. 	

CAT. No. RE10266 45° ANGLE ATTACHMENT KC-300



35,000 min⁻¹(rpm) Max. (*1)
20,000 min⁻¹(rpm) Max. (*2)

Drive Motor & Control Unit

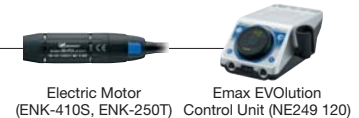

Electric Motor (ENK-410S, ENK-250T) Emax EVOLution Control Unit (NE249 120)

*For the details of above micromotor, refer to the following page (1-p7)

- Ideal for the work at 45° angle, especially corners and deep concaves.



- Use the motor in reverse rotation for clockwise rotation.
- Speed Reduction Ratio : 3/4
- Weight : 1.59 oz.
- Collet
Standard Size : $\phi 1/8"$ (CHC-3.175)
Optional Collets : CHC-□□ are shown in page (6-p2)

45° Angle Attachment

CAT. No.	Model	Standard Accessories	Price
RE10266	KC-300	<ul style="list-style-type: none"> • Collet $\phi 1/8"$ (CHC-3.175) : 1 pc. • Standard Accessories : 1 set • Chuck Wrench (K-231) : 1 pc. • Pin Wrench (K-233) : 1 pc. 	

Standard Accessories for IC-300 and KC-300

Description	CAT. No.	Model	O.D.	Grits	Q'ty	
Rubber Pad	(Small)	RE11915	—	$\phi 10$ mm ($\phi 0.39"$)	—	1
	(Med)	RE11916	—	$\phi 20$ mm ($\phi 0.79"$)	—	1
	(Large)	RE11917	—	$\phi 30$ mm ($\phi 1.18"$)	—	1
Sandpaper Disk	LS10904	S-018	$\phi 11$ mm ($\phi 0.43"$)	# 180	5	
	LS10910	S-060	$\phi 11$ mm ($\phi 0.43"$)	# 600	5	
	RE11804	M-018	$\phi 21$ mm ($\phi 0.83"$)	# 180	5	
	RE11810	M-060	$\phi 21$ mm ($\phi 0.83"$)	# 600	5	
	RE11904	L-018	$\phi 31$ mm ($\phi 1.22"$)	# 180	5	
	RE11910	L-060	$\phi 31$ mm ($\phi 1.22"$)	# 600	5	

*Maximum Allowable Speed, continuous use may change depending on the material being cut and other application variables.

*1 : Maximum Allowable Speed, intermittent use.
*2 : Maximum Allowable Speed, continuous use.



"Emax EVOLution" ACCESSORIES

Optional Accessories for IC-300 and KC-300

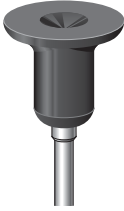
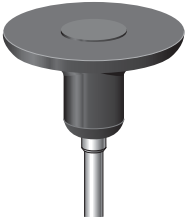
Rubber Pad

Product	Description	CAT. No.	Model	O.D.	Grits	package	Price
	Rubber Pad (Small)	RE11915	--	ø10 mm (ø0.39")	-	1 pc./pack	
	Rubber Pad (Med)	RE11916	--	ø20 mm (ø0.79")	-	1 pc./pack	
	Rubber Pad (Large)	RE11917	--	ø30 mm (ø1.18")	-	1 pc./pack	

Sandpaper Disk (Paper Type for Metals, Adhesive Back)

Product	Description	CAT. No.	Model	O.D.	Grits	package	Price
	Sandpaper Disk for small pad	LS10900	S-008	ø11 mm (ø0.43")	# 80		
		LS10902	S-012		# 120		
		LS10904	S-018		# 180		
		LS10905	S-024		# 240		
		LS10906	S-032		# 320		
		LS10908	S-040		# 400		
		LS10910	S-060		# 600		
		LS10912	S-080		# 800		
		LS10914	S-100		#1,000		
	Sandpaper Disk for med. pad	RE11800	M-008	ø21 mm (ø0.83")	# 80	100 pcs./pack	
		RE11802	M-012		# 120		
		RE11804	M-018		# 180		
		RE11805	M-024		# 240		
		RE11806	M-032		# 320		
		RE11808	M-040		# 400		
		RE11810	M-060		# 600		
		RE11812	M-080		# 800		
		RE11814	M-100		#1,000		
	Sandpaper Disk for large pad	RE11900	L-008	ø31 mm (ø1.22")	# 80		
		RE11902	L-012		# 120		
		RE11904	L-018		# 180		
		RE11905	L-024		# 240		
		RE11906	L-032		# 320		
		RE11908	L-040		# 400		
		RE11910	L-060		# 600		
		RE11912	L-080		# 800		
		RE11914	L-100		#1,000		
RE11925	L-150	#1,500					

1
EmaxEVO
ESPERT
ROTUS
ECOMO
IMPULSE
PRESTO II
SHEENUS neo
SONIC CUTTER
2
iSpeed
E2530
E2550
E3000
E3200
E4000
3
MA SERIES
ø0.897"
ø1.0"
ø0.98"
ø1.18"
MS SERIES
ø0.75"
ø0.79"
ø0.87"
ø0.91"
ø1.0"
ø0.98"
ø1.18"
HIGH SPEED
AMX
4
HES
HTS
HPS
SMS
PL
5
AIR LINE KIT
6
PARTS
7
TECHNICAL DATA
8
APPLICATION EXAMPLES
INDEX

"Emax EVOLution" ATTACHMENTS

The Features of LUSTER Emax EVOLution NLS-110 (Built-in Motor)

NEW



● **Stroke Range : 0-6 mm adjustable by stroke cam**

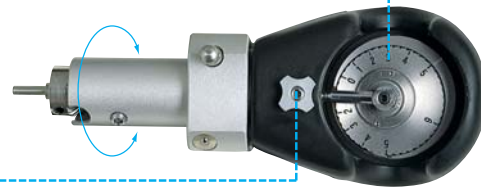

● **The tilt angle of grindstone arbor is adjustable.**
The grinding surface can be set at any angle between 0 and 360° enabling grinding of bottom, right, left and top surfaces without moving the machine itself.

- **NAKANISHI Smart Switch**
- **High Power**
LUSTER (NLS-110) is a powerful reciprocating stroke polisher equipped with 1/4 Speed Reducer to multiply the torque by 4 times.
- **Reciprocating Stroke : 0-7,600 times/min. Fully adjustable.**
- **Ultra-Precision Grinder**
All important parts are hardened by heat treatment to provide excellent durability.
- **Designed with comfortable rubber-grip**
Well balanced, rubber-grip absorbs vibration from reciprocating strokes reducing fatigue and allowing long, continuous operation.



Control Unit



Emax EVOLution Control Unit (NE249 120)

- Weight : 1 lb. 12.22 oz.
- Max. tool shank diameter $\phi 0.25"$, Screw clamp type.
- Various types of attachment tools are provided as standard accessories.

Reciprocating Motion Polishing Finisher LUSTER

CAT. No.	Model	Standard Accessories	Price
1483	NLS-110	<ul style="list-style-type: none"> • Standard Accessories : 1 set • Allen Wrench (2 mm) : 1 pc. • Lubrication Oil • Lubrication Nozzle for LUSTER 	

30,000 min⁻¹(rpm) Max. (*1)

The Features of LUSTER LS-100



● **Stroke Range : 0-6 mm adjustable by stroke cam**

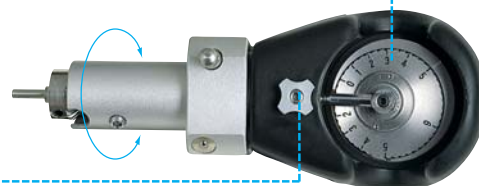

● **The tilt angle of grindstone arbor is adjustable.**
The grinding surface can be set at any angle between 0 and 360° enabling grinding of bottom, right, left and top surfaces without moving the machine itself.

- **High Power**
LUSTER (LS-100) is a powerful reciprocating stroke polisher.
- **Reciprocating Stroke : 0-7,600 times/min. Fully adjustable.**
- **Ultra-Precision Grinder**
All important parts are hardened by heat treatment to provide excellent durability.
- **Designed with comfortable rubber-grip**
Well balanced, rubber-grip absorbs vibration from reciprocating strokes reducing fatigue and allowing long, continuous operation.



Drive Motor & Control Unit



Electric Motor (ENK-410S, ENK-250T) Emax EVOLution Control Unit (NE249 120)

*For the details of above micromotor, refer to the following page (1-p7)

- Weight : 1 lb. 7.99 oz.
- Max. tool shank diameter $\phi 0.25"$, Screw clamp type.
- Various types of attachment tools are provided as standard accessories.

Reciprocating Motion Miniature Polisher LUSTER

CAT. No.	Model	Standard Accessories	Price
LS10815	LS-100	<ul style="list-style-type: none"> • Standard Accessories : 1 set • Allen Wrench (2 mm) : 1 pc. • Lubrication Oil • Lubrication Nozzle for LUSTER 	

30,000 min⁻¹(rpm) Max. (*1)

1

EmaxEVO
ESPERT
ROTUS
ECOMO
IMPULSE
PRESTO II
SHEENUS
ed
SONIC
CUTTER

2

iSpeed
E2530
E2550
E3000
E3200
E4000

3

MA
SERIES
 $\phi 0.897"$
 $\phi 1.0"$
 $\phi 0.98"$
 $\phi 1.18"$
MS
SERIES
 $\phi 0.75"$
 $\phi 0.79"$
 $\phi 0.87"$
 $\phi 0.91"$
 $\phi 1.0"$
 $\phi 0.98"$
 $\phi 1.18"$

HIGH
SPEED
AMX

4

HES
HTS
HPS
SMS
PL

5

AIR LINE KIT

6

PARTS

7

TECHNICAL
DATA

8

APPLICATION
EXAMPLES
INDEX

"Emax EVOLution" ATTACHMENTS

The Features of MINI-LUSTER ML-8



Drive Motor & Control Unit

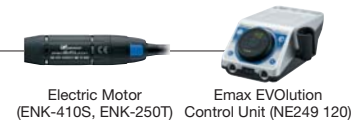

*For the details of above micromotor, refer to the following page (1-p7)

- Reciprocating Stroke (variable) : Approx 0~9,000 times/min.
- Stroke Range (fixed) : 0.8 mm.
- Due to pencil type grip, it is most suitable for polishing narrow grooves, details, etc.
- Lightweight, compact design and minimal vibration keep the hand free from fatigue for long continuous operation.
- By using the grindstone holder provided, various tools such as oil stone, super stone, diamond files, etc. can be used.



- Weight : 4.59 oz.
- Max. tool shank diameter $\phi 0.13"$, Screw clamp type.
- Various attachment tools and holders are provided as standard accessories.

Pencil-Type Reciprocating Polishing Finisher MINI-LUSTER Attachment

CAT. No.	Model	Stroke Range	Standard Accessories	Price
LS51307	ML-8	0.8mm	<ul style="list-style-type: none"> • Standard Accessories : 1 set • Allen Wrench (1.5 mm) : 1 pc. 	

35,000 min⁻¹(rpm) Max. (*1) 30,000 min⁻¹(rpm) Max. (*2)

The Features of SWING-LUSTER SLS-16



Drive Motor & Control Unit

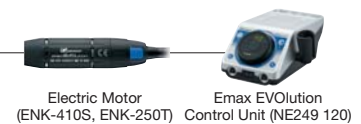

*For the details of above micromotor, refer to the following page (1-p7)

- High speed grinding and polishing operations can be performed while maintaining the fine and delicate feeling of hand polishing.
- Lightweight pencil type design makes it easy to work in tight areas.
- Ergonomically designed to provide high sensitivity for precision work.
- Easily adjustable stroke length allows efficient work on minute areas or large sections.

- Weight : 4.48 oz.
- Reciprocating Stroke (variable) : 0~9,000 times/min
- Stroke range (variable) : 0~1.6 mm
- Max. tool shank diameter $\phi 0.20"$, Screw clamp type.

Pencil-Type Reciprocating Polishing Finisher SWING-LUSTER Attachment

CAT. No.	Model	Standard Accessories	Price
LS11380	SLS-16	<ul style="list-style-type: none"> • Standard Accessories : 1 set • Allen Wrench (1.5 mm) : 1 pc. 	

35,000 min⁻¹(rpm) Max. (*1)

AMERICAN ROTARY TOOLS CO.

Toll Free USA Tel: (800) 624-2212

*Maximum Allowable Speed, continuous use may change depending on the material being cut and other application variables.

*1 : Maximum Allowable Speed, intermittent use.
*2 : Maximum Allowable Speed, continuous use.













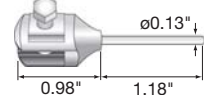

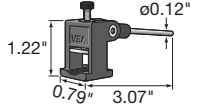



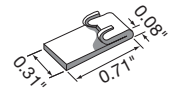

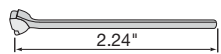
1
EmaxEVO
ESPERT
ROTUS
ECOMO
IMPULSE
PRESTO II
SHEENUS 1190
SONIC CUTTER
2
iSpeed
E2530
E2550
E3000
E3200
E4000
3
MA SERIES
$\phi 0.897"$
$\phi 1.0"$
$\phi 0.98"$
$\phi 1.18"$
MS SERIES
$\phi 0.75"$
$\phi 0.79"$
$\phi 0.87"$
$\phi 0.91"$
$\phi 1.0"$
$\phi 0.98"$
$\phi 1.18"$
HIGH SPEED
AMX
4
HES
HTS
HPS
SMS
PL
5
AIR LINE KIT
6
PARTS
7
TECHNICAL DATA
8
APPLICATION EXAMPLES
INDEX

"Emax EVOLution" ACCESSORIES

- 1**
- EmaxEVO
- ESPERT
- ROTUS
- ECOMO
- IMPULSE
- PRESTO II
- SHEENUS
- SONIC CUTTER
- 2**
- iSpeed
- E2530
- E2550
- E3000
- E3200
- E4000
- 3**
- MA SERIES
- ø0.89"
- ø1.0"
- ø0.98"
- ø1.18"
- MS SERIES
- ø0.75"
- ø0.79"
- ø0.87"
- ø0.91"
- ø1.0"
- ø0.98"
- ø1.18"
- HIGH SPEED
- AMX
- 4**
- HES
- HTS
- HPS
- SMS
- PL
- 5**
- AIR LINE KIT
- 6**
- PARTS
- 7**
- TECHNICAL DATA
- 8**
- APPLICATION EXAMPLES
- INDEX

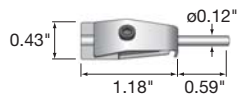
Tool and standard accessories for LUSTER, MINI-LUSTER, SWING-LUSTER

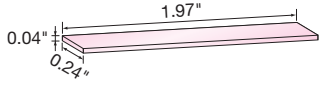
• Each product is provided with tool  as standard.

Product	Model	CAT. No.	Price (Package)	LUSTER NLS-110 LS-100	MINI-LUSTER ML-8	SWING-LUSTER SLS-16
Max. clampable size : Thickness 0.08" x width 0.51" 	Grindstone Holder	62501	(3 pcs./pack)	 (1 pc.)		
Max. clampable size : Thickness 0.18" x width 0.43" 	Grindstone Holder VES	LS10875	(1 pc./pack)	 (1 pc.)		
Max. clampable size : Thickness 0.43" x width 0.53" 	Grindstone Holder VEA	LS10834	(1 pc./pack)	 (1 pc.)		
[4] 	Tool Holder with Spring FVA	LS10867	(1 pc./pack)	 (1 pc.)	 (1 pc.)	
[1] 	Rectangular Pad LKE-2A	LS10891	(1 pc./pack)	 (1 pc.)		
[2] 	Rod for Rectangular Pad FBA-2	LS10848	(1 pc./pack)	 (1 pc.)		
[3] 	Angle Rod NGA	LS10853	(1 pc./pack)	 (1 pc.)		
	Diamond Grindstone DLA4 x 1-100	LS10918	(1 pc./pack)		 (1 pc.)	 (1 pc.)
Max. clampable size : Thickness 0.14" x width 0.79" 	Grindstone Holder	62951	(3 pcs./pack)		 (1 pc.)	 (1 pc.)
	Ceramic Fiber Grindstone (#1,200)	60737	(2 pcs./pack)		 (1 pc.)	 (1 pc.)

● Illustration Usage

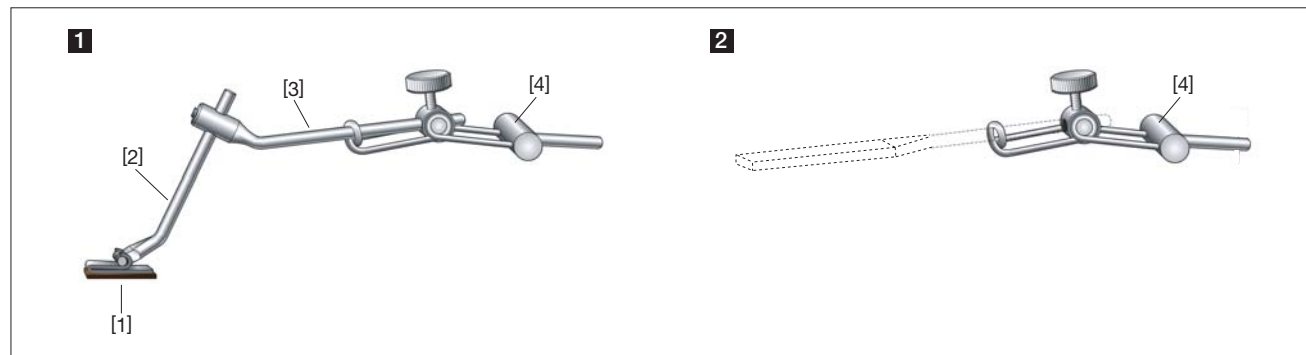

“Emax EVOLution” ATTACHMENTS

1

- EmaxEVO
- ESPERT
- ROTUS
- ECOMO
- IMPULSE
- PRESTO II
- SHEENUS neo
- SONIC CUTTER
- 2
- iSpeed
- E2530
- E2550
- E3000
- E3200
- E4000
- 3
- MA SERIES
- ø0.897"
- ø1.0"
- ø0.98"
- ø1.18"
- MS SERIES
- ø0.75"
- ø0.79"
- ø0.87"
- ø0.91"
- ø1.0"
- ø0.98"
- ø1.18"
- HIGH SPEED
- AMX
- 4
- HES
- HTS
- HPS
- SMS
- PL
- 5
- AIR LINE KIT
- 6
- PARTS
- 7
- TECHNICAL DATA
- 8
- APPLICATION EXAMPLES
- INDEX

The Features of HA-500



Drive Motor & Control Unit

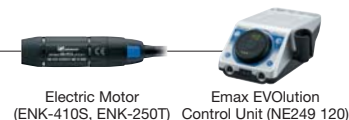

Electric Motor (ENK-410S, ENK-250T) Emax EVOLution Control Unit (NE249 120)

*For the details of above micromotor, refer to the following page (1-p7)

- Stroke speed : 25~5,000 strokes/min
- A wide variety of patterns can be produced by varying the spring pressure and hammer speed.
- Light weight, pencil type grip makes the handpiece very comfortable to hold and easy to use.
- Adjustable spring pressure.
- Self lubricating hammer mechanism ensure excellent durability.

- Weight : 3.35 oz.
- Stroke range : 0.4 mm • Stroke Spring Pressure : 4.4~7.1N (Ring Adjustment Type)

Engraving and Ornament Processing Work Hammer Attachment

CAT. No.	Model	Standard Accessories	Price
RE18060	HA-500	<ul style="list-style-type: none"> • Wrench (7 x 5.1) : 1 pc. • Bar Wrench (K-212) : 1 pc. • Oil and Oil offer machine • Hammer Bit (For replacement) : 2 pcs. 	

20,000 min⁻¹(rpm) Max. (*1) 16,000 min⁻¹(rpm) Max. (*2)

Hammer Bit to be machined to required shapes (SUS-420, heat treated, approx, HRC50)

Product	CAT. No.	Package	Price
	RE65301	3 pcs./pack	

The Features of FINE BELT SANDER KBS-101

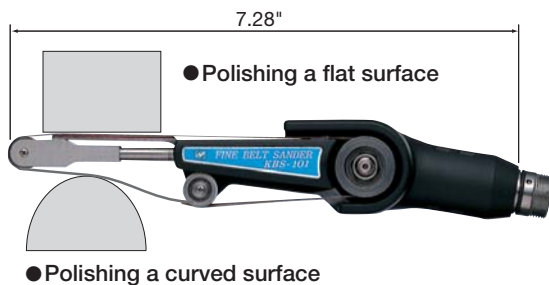

Drive Motor & Control Unit

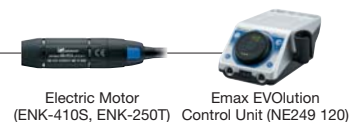

Electric Motor (ENK-410S, ENK-250T) Emax EVOLution Control Unit (NE249 120)

*For the details of above micromotor, refer to the following page (1-p7)

- Belt runs Approx. 0~2,700 ft/min
- 8 mm, 6 mm and 4 mm width belts are available.
- The angle of the belt section is fully adjustable.
- Exchanging the belt is simply done by lever release.
- Weight : 12.35 oz.
- Light-weight, compact, minimal vibration and a small diameter grip design keep the hand free from fatigue for long, continuous operation.
- When polishing a curved surface, the tension between the front and central pulley can be utilized. When polishing a flat surface or a groove, use the flat part of belt.







FINE BELT SANDER Attachment

CAT. No.	Model	Standard Accessories	Price
KBS61065	KBS-101	<ul style="list-style-type: none"> • 8 mm Belt (3 kinds 2 pcs. each) • 6 mm Belt (3 kinds 2 pcs. each) • 4 mm Belt (3 kinds 2 pcs. each) • Allen Wrench (3 mm) : 1 pc. 	

35,000 min⁻¹(rpm) Max. (*1)

"Emax EVOLution" ACCESSORIES

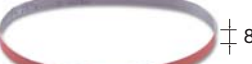
Belt for FINE BELT SANDER (Ring Type)

Product	Description	CAT. No.	Grit	Width (mm)	Length (mm)	Package	Price (Package)
	Sand Belt	64901	# 80	4	300	30 pcs./pack	
		64210	# 120				
		64903	# 180				
		64211	# 240				
		64905	# 320				
		64212	# 400				
		64911	# 80	6			
		64201	# 120				
		64913	# 180				
		64202	# 240				
		64915	# 320				
		64203	# 400				
		64921	# 80	8			
		64220	# 120				
		64923	# 180				
	64221	# 240					
	64925	# 320					
	64222	# 400					
	64927	# 600					
64928	# 800						
Sand Belt for Wood	64941	# 80					
	64942	# 120					
	64943	# 240					
	Zirconia	64971	# 80	8	300	30 pcs./pack	
		64972	# 100				
		64973	# 120				
	Diamond (Hard Type)	65011	# 80	8	300	3 pcs./pack	
		65012	# 120				
		65014	# 240	8			
		65015	# 320				
		65017	# 600				
	Diamond (Soft Type)	65021	# 120	8	300	3 pcs./pack	
		65022	# 180				
		65023	# 240				
		65024	# 320				
		LS65028	# 400	8			
		65025	# 600				
		LS65026	# 800				
		65027	#1,000				
	Felt	65101	—	8	300	5 pcs./pack	

AMERICAN ROTARY TOOLS CO.

Toll Free USA Tel: (800) 624-2212

* Order by catalog number. 1-p17

1

EmaxEVO

ESPERT

ROTUS

ECOMO

IMPULSE

PRESTO II

SHEENUS neo

SONIC CUTTER

2

iSpeed

E2530

E2550

E3000

E3200

E4000

3

MA SERIES

ø0.897"

ø1.0"

ø0.98"

ø1.18"

MS SERIES

ø0.75"

ø0.79"

ø0.87"

ø0.91"

ø1.0"

ø0.98"

ø1.18"

HIGH SPEED

AMX

4

HES

HTS

HPS

SMS

PL

5

AIR LINE KIT

6

PARTS

7

TECHNICAL DATA

8

APPLICATION EXAMPLES

INDEX

“Emax EVOLution” SPEED REDUCER & PARTS

1

EmaxEVO
 EXPERT
 ROTUS
 ECOMO
 IMPULSE
 PRESTO II
 SHEENUS
 ed
 SONIC
 CUTTER

CAT. No. RO10214 SPEED REDUCER RG-01



TORQUE UP 4 TIMES
 (1/4 Speed Reducer)

● The speed is reduced to 1/4 but the torque is multiplied by 4 times.

• Weight : 2.40 oz.

30,000 min⁻¹(rpm) Max. (*1)

Speed Reducer (1/4)

CAT. No.	Model	Standard Accessories	Price
RO10214	RG-01	• Pin Wrench (K-233) : 1 pc.	

CAT. No. RO10228 SPEED REDUCER RG-02



TORQUE UP 15 TIMES
 (1/15 Speed Reducer)

● The speed is reduced to 1/15 but the torque is multiplied by 15 times.

• Weight : 3.28 oz.

30,000 min⁻¹(rpm) Max. (*1)

Speed Reducer (1/15)

CAT. No.	Model	Standard Accessories	Price
RO10228	RG-02	• Pin Wrench (K-233) : 1 pc.	

2

iSpeed
 E2530
 E2550
 E3000
 E3200
 E4000

3

MA SERIES
 ø0.897"
 ø1.0"
 ø0.98"
 ø1.18"
 MS SERIES
 ø0.75"
 ø0.79"
 ø0.87"
 ø0.91"
 ø1.0"
 ø0.98"
 ø1.18"
 HIGH SPEED
 AMX

CAT. No. RE10210 EXTENSION JOINT CN-01



(Speed 1 : 1)

● This is a joint to be connected between a motor and an attachment to extend the total length of the attachment.

• Weight : 2.93 oz.

35,000 min⁻¹(rpm) Max. (*1)

Extension Joint (Speed 1 : 1)

CAT. No.	Model	Standard Accessories	Price
RE10210	CN-01	• Pin Wrench (K-233) : 1 pc.	

4

HES
 HTS
 HPS
 SMS
 PL

CAT. No. 8106 FOOT PEDAL FC-64



● Used as an ON/OFF switch as well as a variable speed control.

Foot Pedal

CAT. No.	Model	Fit to	Price
8106	FC-64	Emax EVOLution	

5

AIR LINE KIT

6

PARTS

7

TECHNICAL DATA





8

APPLICATION EXAMPLES

INDEX

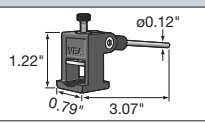
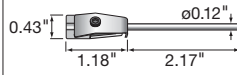
"Emax EVOLution" ACCESSORIES

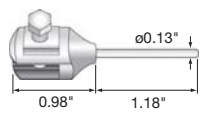
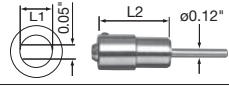
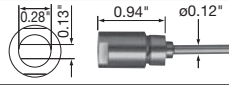

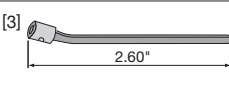
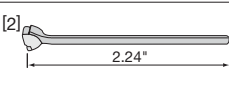
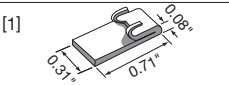
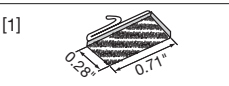
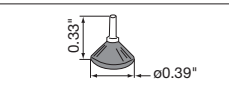
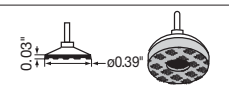
Common Tools for LUSTER, MINI-LUSTER

Product	CAT. No.	Description · Model	Price
	LS 10834	Grindstone Holder VEA for (W 0.53" x T 0.43")	
	62501	Grindstone Holder for (W 0.51" x T 0.08")	
	62951	Grindstone Holder for (W 0.79" x T 0.14")	
	LS 10875	Grindstone Holder VES for (W 0.43" x T 0.18")	
	ZO 94005 94006 94007	Holder for Super Stone SH-10 (L1=0.40" (L2=1.00") SH-6 (L1=0.24" (L2=0.92") SH-4 (L1=0.16" (L2=0.87")	*1
	ZO 95008	Oil Stone Lapping Stick Holder for (W 0.24" x T 0.12")	
	LS 10867	Tool Holder with Spring FVA	
	LS 10853	Angle Rod NGA	
	LS 10848	Rod for Lapping FBA-2	
	LS 10891	LKE-2A with Hinge Use with FBA-2	
	LS 11326	Hinge (Diamond) DLC-7 x 18-100	*2
	LS 10886	Ball Joint LAA-3A Use with SEV	*2
	LS 11327	Ball Joint (with Diamond) DLD-10/0.75	*2

[1]-[4] : Please See Page 1-p14 for Illustration Usage.

*1 : Other than noted, prices are per piece.

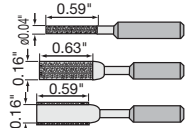
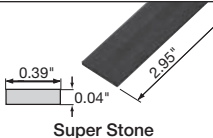
*2 : Available while supply lasts. Check with NSK America.

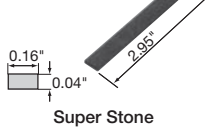
Product	CAT. No.	Description · Model	Price
	LS10900	S-008 # 80	100 pcs. Package
	LS10902	S-012 # 120	
	LS10904	S-018 # 180	
	LS10905	S-024 # 240	
	LS10906	S-032 # 320	
	LS10908	S-040 # 400	
	LS10910	S-060 # 600	
	LS10912	S-080 # 800	
	LS10914	S-100 # 1,000	
	LS10915	S-150 # 1,500	
	LS10917	K-008 # 80	100 pcs. Package
	LS10919	K-012 # 120	
	LS10921	K-018 # 180	
	LS10924	K-024 # 240	
	LS10923	K-032 # 320	
	LS10925	K-040 # 400	
	LS10927	K-060 # 600	
	LS10929	K-080 # 800	
	LS10931	K-100 # 1,000	
	LS10932	K-150 # 1,500	
	LS10963	DLA-1-100	
	LS10918	DLA4 x 1-100	
	LS10922	DLA1 x 4-100	
	LS26712	Black # 600	*2
	LS26707	Blue # 800	*2
	LS26708	White # 1,000	*2
	LS26709	Red # 1,200	*2
	LS26711	Black # 600	*2
	LS26704	Blue # 800	*2
	LS26705	White # 1,000	*2
	LS26706	Red # 1,200	*2
	LS26710	Black # 600	*2
	LS26701	Blue # 800	*2
	LS26702	White # 1,000	*2
	LS26703	Red # 1,200	*2